

GATE VALVE

OVERVIEW (Pressure Seal Bonnet)

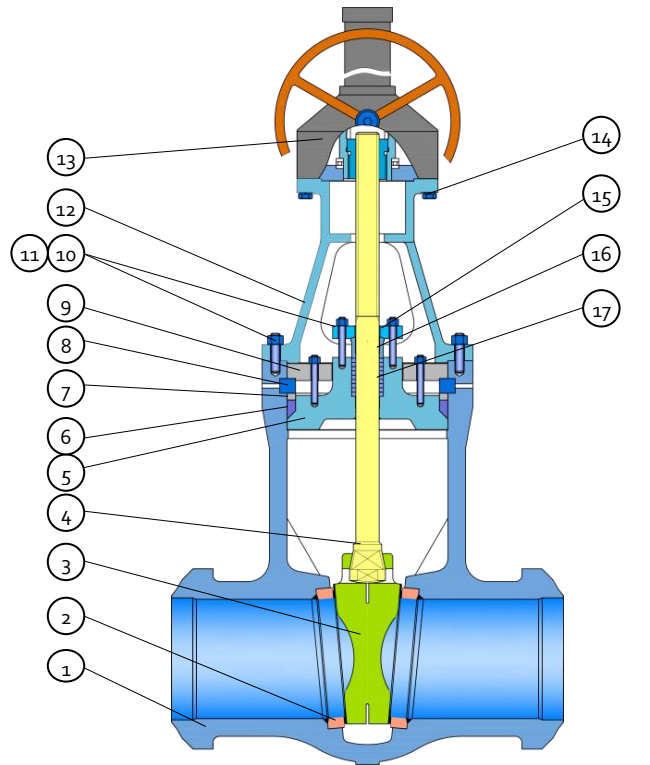

Part List

1 Body	5 Bonnet	9 Push Plate	13 Gear
2 Seat	6 Seal ring	10 Stud	14 Bolt
3 Wedge	7 Push ring	11 Nut	15 Gland flange
4 Stem	8 Split ring	12 Yoke	16 Gland

Standards

Design & Manufacture	ASME B16.34, MSS SP-144	
Face-to-face	ASME B16.10	
End Dimension	ASME B16.5(RF, RTJ) ASME B16.47(RF, RTJ) ASME B16.25 (BW)	
Test & Inspection	API 598, ASME B16.34	
Typical Materials	Body, Bonnet, Disc	(Casting) A216 WCB, A351 CF3, CF8, CF3M, CF8M, A995 4A, 5A, A352 LCB, LCC, LC (Forging) A105, A350 LF2, LF3, LF5, A182 F304, F304L, F316, F316L, F51, F53, F5, F11, F22, F91, Monel, Inconel, Hastelloy
	Stem	A182 F6a, F304, F304L, F316, F316L, F51, F53, F55 Monel, Inconel, Hastelloy

GATE VALVE

DIMENSIONS AND WEIGHTS (Pressure Seal Bonnet)

ASME CLASS 900 (PN 150)

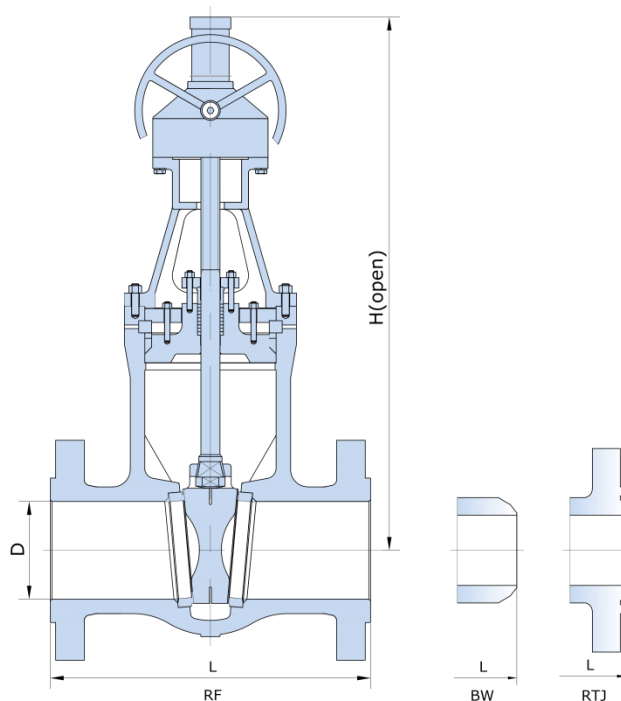

ASME CLASS 900 (PN 150)

Size in/mm	D	L			H	W	Weight
		RF	RTJ	BW			RF/BW (lb/kg)
2	1.87	14.5	14.63	8.5	19.62	7.87	163/119
50	47.5	368	371	216	498	200	74/54
2 1/2	2.24	16.5	16.62	10	21.5	9.84	222/172
65	57	419	422	254	547	250	101/78
3	2.87	15	15.13	12	22.5	11.81	289/231
80	73	381	384	305	573	300	131/105
4	3.86	18	18.13	14	26.62	17.72	379/297
100	98	457	460	356	678	450	172/135
5	4.76	22	22.13	17	35.5	19.7	615/463
125	121	559	562	432	900	500	276/210
6	5.75	24	24.13	20	38.2	19.7	378/573
150	146	610	613	508	970	500	335/260
8	7.48	29	29.13	26	43.5	23.62	1410/1134
200	190	737	740	660	1103	600	640/515
10	9.37	33	33.13	31	53	-	2423/2026
250	238	838	841	787	1345	-	1100/920
12	11.1	38	38.13	36	60	-	3546/3040
300	282	965	968	914	1525	-	1600/1380
14	12.24	40.5	40.88	39	74.5	-	4956/4427
350	311	1029	1038	991	1900	-	2250/2010
16	14	44.5	44.88	43	81	-	6278/5650
400	356	1130	1140	1092	2055	-	2850/2565
18	15.75	48	48.5	-	87	-	6740/5474
450	400	1219	1232	-	2215	-	3060/2485
20	17.52	52	52.5	-	101	-	8447/7159
500	445	1321	1334	-	2565	-	3835/3250
24	21	61	61.75	-	104	-	10793/8954
600	533	1549	1568	-	2640	-	4900/4065

The dimension and weights are for reference only and subject to change without notice.

- For more dimensional information, please contact our sales representative.
- "W" on above schematic is the diameter for hand wheel, the one without dimension on the table above is defaulted by gear operation.

GATE VALVE

DIMENSIONS AND WEIGHTS (Pressure Seal Bonnet)

ASME CLASS 1500 (PN 250)

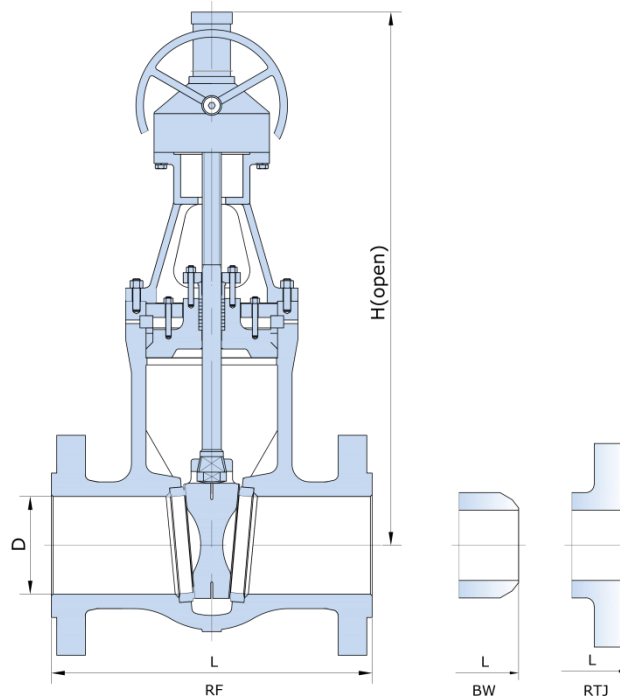

ASME CLASS 1500 (PN 250)

Size in/mm	D	L			H	W	Weight
		RF	RTJ	BW			RF/RTJ (lb/kg)
2	1.87	14.5	14.61	8.5	24.25	10	256/231
50	47.5	368	371	216	615	250	116/105
2 1/2	2.24	16.5	16.61	10	26	12	366/330
65	57	419	422	254	658	300	166/150
3	2.76	18.5	18.62	12	30	18	460/414
80	70	470	473	305	760	450	209/188
4	3.58	21.5	21.61	16	34.12	20	652/584
100	91	546	549	406	868	500	296/265
5	4.73	26.5	26.61	19	38.4	24	958/826
125	111	673	676	483	975	600	435/375
6	5.35	27.75	28	22	39.5	24	1123/907
150	136	705	711	559	1005	600	510/412
8	7	32.75	33.15	28	45	-	2026/1586
200	178	832	842	711	1145	-	920/760
10	8.74	39	39.41	34	54	-	4207/3610
250	222	991	1001	864	1370	-	1910/1640
12	10.35	44.5	45.12	39	61	-	6947/6068
300	263	1130	1146	991	1650	-	3154/2755
14	11.38	49.5	50.24	42	74.88	-	9031/7048
350	289	1259	1276	1067	1900	-	4100/3200
16	13	54.5	55.35	47	80.5	-	13656/11674
400	330	1384	1406	1194	2050	-	6200/5300
18	14.61	60.5	61.38	53	93.75	-	19747/17775
450	371	1537	1559	1346	2350	-	8965/8070
20	16.38	65.5	66.38	58	101.5	-	28855/25969
500	416	1664	1686	1473	2580	-	13100/11790
24	19.61	76.5	77.6	-	114.75	-	34934/31443
600	498	1943	1971	-	2915	-	15860/14275

The dimension and weights are for reference only and subject to change without notice.

- For more dimensional information, please contact our sales representative.
- "W" on above schematic is the diameter for hand wheel, the one without dimension on the table above is defaulted by gear operation.

GATE VALVE

DIMENSIONS AND WEIGHTS (Pressure Seal Bonnet)

ASME CLASS 2500 (PN 420)

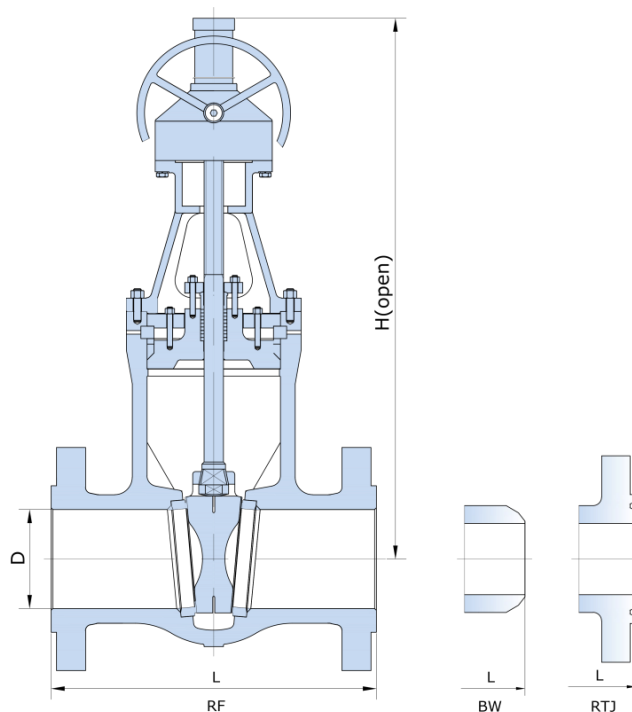

ASME CLASS 2500 (PN 420)

Size in/mm	D	L			H	W	Weight
		RF	RTJ	BW			RF/RTJ (lb/kg)
2	1.5	17.75	17.88	11	23.38	13.78	253/143
50	38	451	454	279	595	350	115/65
2 1/2	1.89	20.32	20.56	13	25.6	17.72	300/172
65	48	508	514	330	650	450	136/78
3	2.24	22.75	23	14.5	28	17.72	540/385
80	57	578	584	368	710	450	245/175
4	2.87	26.5	26.88	18	32.25	19.69	1079/826
100	73	673	683	457	820	500	490/375
5	3.62	31.26	31.77	521	43.3	23.62	1476/974
125	92	794	807	33	1100	600	670/430
6	4.37	36	36.5	24	49.62	23.62	1894/1278
150	111	914	927	610	1260	600	860/580
8	5.75	40.25	40.88	30	63.4	-	5396/4405
200	146	1022	1038	762	1610	-	2450/2010
10	7.27	50	50.88	36	81.7	-	10066/8370
250	184	1270	1292	914	2076	-	4570/3800
12	8.62	56	56.88	41	89.8	-	13436/11454
300	219	1422	1444	1041	2281	-	6100/5200
14	9.49	-	-	44	74.88	-	-
350	241	-	-	1118	1900	-	-
16	10.87	-	-	49	80.5	-	-
400	276	-	-	1245	2050	-	-
18	12.24	-	-	55	93.75	-	-
450	311	-	-	1397	2350	-	-

The dimension and weights are for reference only and subject to change without notice.

- For more dimensional information, please contact our sales representative.
- “W” on above schematic is the diameter for hand wheel, the one without dimension on the table above is defaulted by gear operation.

GATE VALVE

OVERVIEW (Special Type Cast Steel Gate Valve)

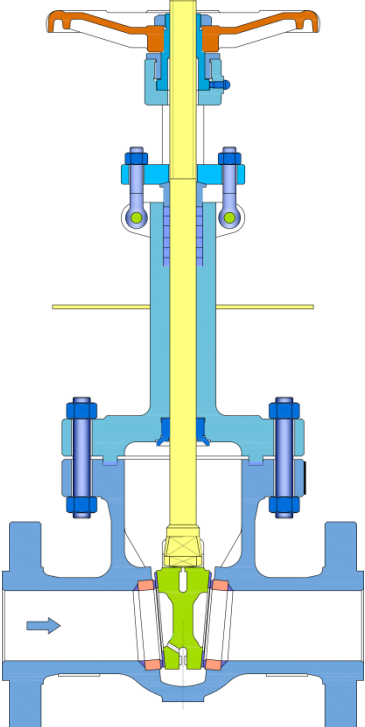
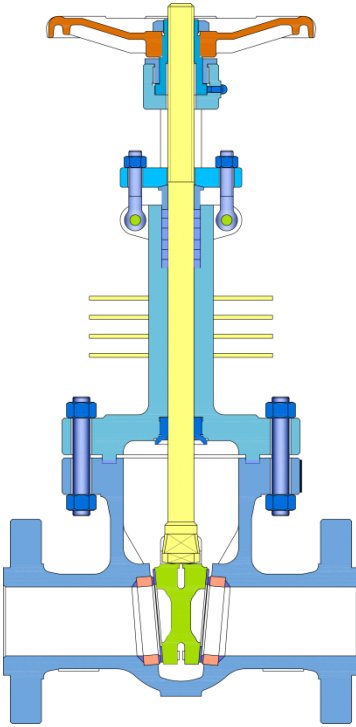
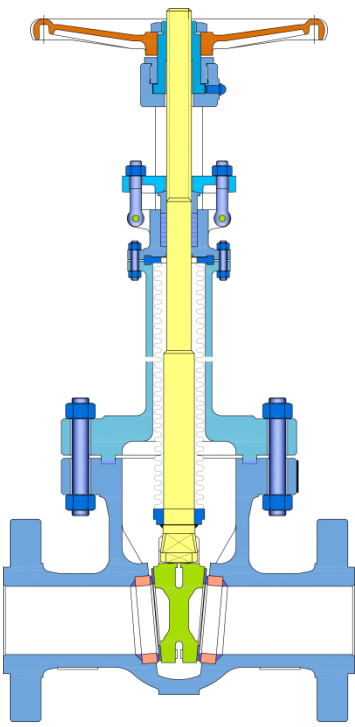
		
<p>Low Temperature Extension</p>	<p>High Temperature Extension</p>	<p>Bellow Seal Extension</p>
<p>Structure characteristics:</p> <ol style="list-style-type: none"> 1. The bonnet are extended for low temperature service, the packing position are raised to avoid the freeze of packing which will affect packing sealing performance; 2. The gate valve shall have relief hole on upstream direction while the pressure may remain in the cavity; 3. Low temperature cold isolation can be an option to prevent cold heat exchange. 	<p>Structure characteristics:</p> <ol style="list-style-type: none"> 1. The high temperature extended structure is mainly to prevent scald operator during operation. 2. The cooling fin can be selected to help heat radiation. 	<p>Structure characteristics:</p> <ol style="list-style-type: none"> 1. Bellow seal extension has the bellow inside of the cavity, the effective compression of the bellows must be greater than the opening stroke of the valve; 2. Bellow seal structure can effectively reduce the leakage of valve stem, the primary seal is for bellows and secondary seal as a filler.