

GLOBE VALVE

OVERVIEW (Bolted Bonnet)

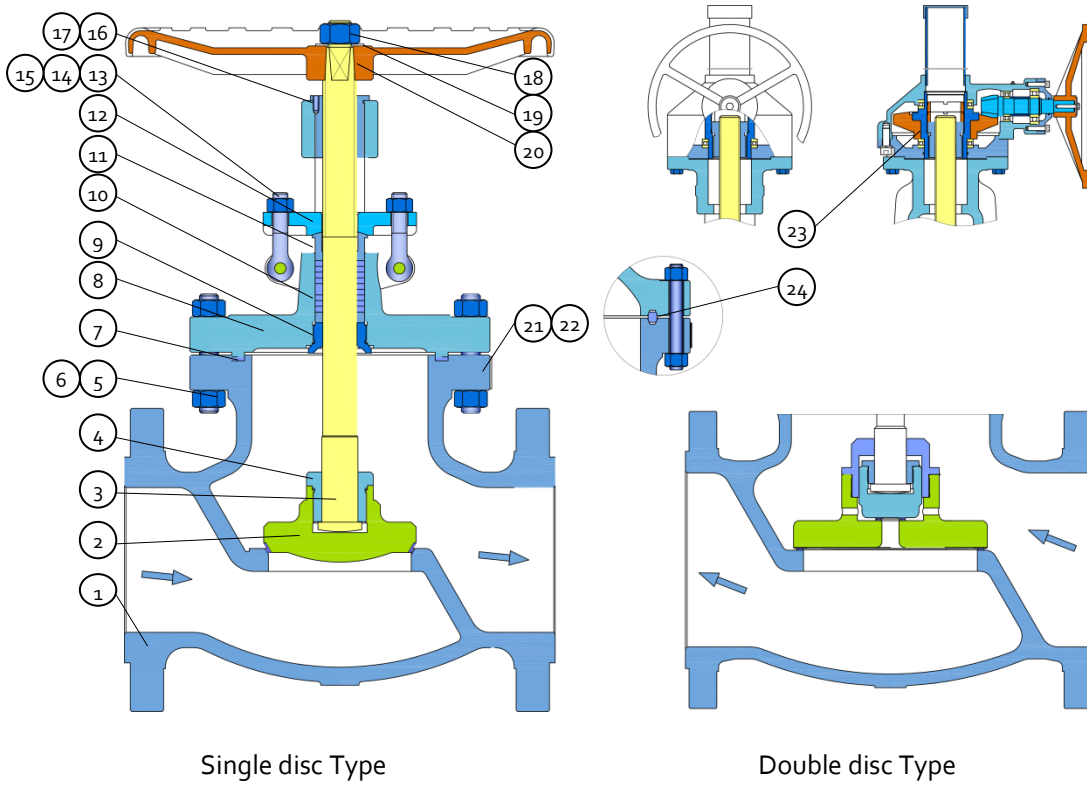

Part List

1 Body	7 Gasket	13 Eye Bolt	19 Washer
2 Disc	8 Bonnet	14 Nut	20 Handwheel
3 Stem	9 Backseat	15 Pin	21 Rivet
4 Sleeve	10 Packing	16 Stem Nut	22 Nameplate
5 Stud	11 Gland	17 Handwheel Nut	23 Gear
6 Nut	12 Gland Flange	18 Nut	24 Octagonal Ring

Standards

Design & Manufacture BS 1873, API 623, ASME B16.34

Face-to-face ASME B16.10

End Dimension ASME B16.5 (RF, RTJ),
ASME B16.47 (RF, RTJ)
ASME B16.25 (BW)

Test & Inspection API 598

Typical Materials

Body, Bonnet, Disc	(Casting): A216 WCB, A351 CF3, CF8, CF3M, CF8M, A995 4A, 5A, A352 LCB, LCC, LC2
	(Forging): A105, A350 LF2, LF3, LF5, A182 F304, F304L, F316, F316L, F51, F53, F5, F11, F22, F91, Monel, Inconel, Hastelloy
Stem	A182 F6a, F304, F304L, F316, F316L, F51, F53, F55 Monel, Inconel, Hastelloy

GLOBE VALVE

DIMENSIONS AND WEIGHTS (Bolted Bonnet)

ASME CLASS 150 (PN 20)

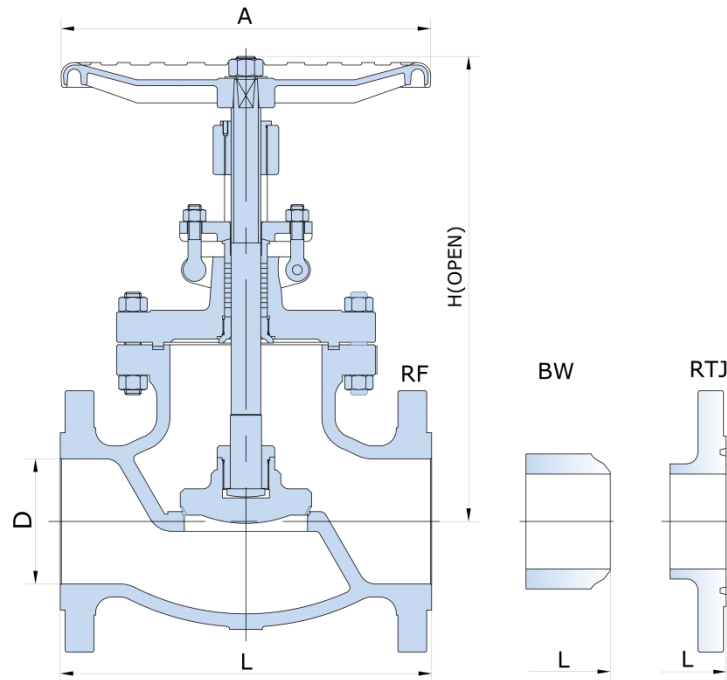

ASME CLASS 150 (PN 20)

Size in/mm	D	L			H	W	Weight
		RF	RTJ	BW			RF/BW (lb/kg)
2	2	8	8.5	8	14.3	7.87	37/34
50	51	203	216	203	363	200	17/15.5
2 1/2	2.5	8.5	9	8.5	15.55	9.84	53/48
65	64	216	229	216	395	250	24/22
3	3	9.5	10	9.5	16.65	9.84	75/68
80	76	241	254	241	423	250	34/31
4	4	11.5	12	11.5	19	11.81	104/95
100	100	292	305	292	483	300	47/43
5	5	14	14.53	14	20.67	15.75	154/141
125	125	356	369	356	525	400	70/64
6	6	16	16.5	16	22.52	15.75	187/172
150	150	406	419	406	572	400	85/78
8	8	19.5	20	19.5	26.65	17.72	275/220
200	203	495	508	495	677	450	125/110
10	10	24.5	25	24.5	32.87	19.69	557/524
250	250	622	635	622	835	500	253/238
12	12	27.5	28	27.5	39.17	23.62	802/753
300	305	698	711	698	995	600	364/342
14	14	31	31.5	31	40.16	-	1123/1048
350	337	787	800	787	1020	-	510/476
16	15.24	36	36.5	36	41.34	-	1630/1487
400	387	914	927	914	1050	-	740/675
18	17.24	38.5	39	38.5	50.6	-	1773/1652
450	438	978	991	978	1285	-	805/750
20	19.25	38.5	39	38.5	58.27	-	1872/1729
500	489	978	991	978	1480	-	850/785
24	23.27	51	51.5	51	68.11	-	2709/2434
600	591	1295	1308	1295	1730	-	1230/1105

The dimension and weights are for reference only and subject to change without notice.

1. For more dimensional information, please contact our sales representative.
2. "W" on above schematic is the diameter for hand wheel, the one without dimension on the table above is defaulted by gear operation.

GLOBE VALVE

DIMENSIONS AND WEIGHTS (Bolted Bonnet)

ASME CLASS 300 (PN 50)

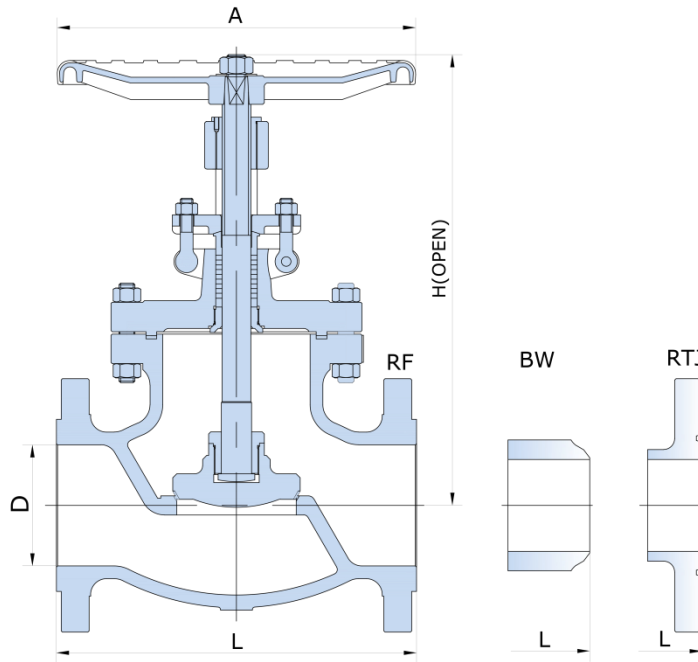

ASME CLASS 300 (PN 50)

Size in/mm	D	L			H	W	Weight
		RF	RTJ	BW			RF/BW (lb/kg)
2	2	10.5	11.14	10.5	14.72	7.87	64/57
50	51	267	283	267	374	200	29/26
2 1/2	2.5	11.5	12.13	11.5	15.55	9.84	84/68
65	64	292	308	292	395	250	35/31
3	3	12.5	13.15	12.5	17.76	11.81	104/90
80	76	318	334	318	451	300	47/41
4	4	14	14.65	14	20.16	13.78	123/112
100	100	356	372	356	512	350	56/51
5	5	15.75	16.38	15.75	21.26	13.78	148/130
125	125	400	416	400	540	350	67/59
6	6	17.5	18.11	17.5	25	17.72	278/253
150	150	444	460	444	635	450	126/115
8	8	22	22.64	22	26.85	19.7	529/474
200	203	559	575	559	682	500	240/215
10	10	24.5	25.12	24.5	32.87	19.7	1233/1167
250	250	622	638	622	835	500	560/530
12	12	28	28.62	28	33.66	19.7	1586/1482
300	305	711	727	711	855	500	720/673
14	14	33	33.62	33	37.4	-	-
350	337	838	854	838	950	-	-
16	15.24	34	34.65	34	43.3	-	-
400	387	864	880	864	1100	-	-
18	17	38.5	39.13	38.5	45.28	-	-
450	432	978	994	978	1150	-	-
20	19	40	40.75	40	47.24	-	-
500	483	1016	1035	1016	1200	-	-
24	23	53	53.86	53	51.18	-	-
600	584	1346	1368	1346	1300	-	-

The dimension and weights are for reference only and subject to change without notice.

1. For more dimensional information, please contact our sales representative.
2. "W" on above schematic is the diameter for hand wheel, the one without dimension on the table above is defaulted by gear operation.

GLOBE VALVE

DIMENSIONS AND WEIGHTS (Bolted Bonnet)

ASME CLASS 600 (PN 100)

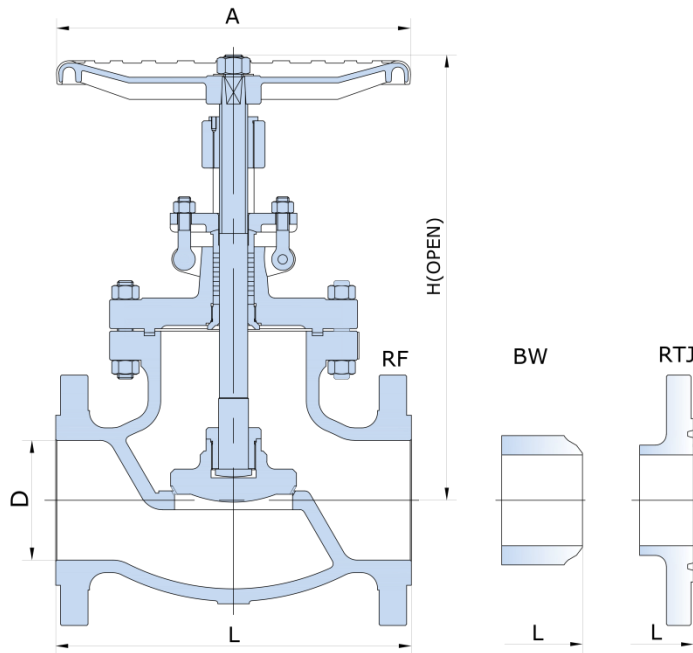

ASME CLASS 600 (PN 100)

Size in/mm	D	L			H	W	Weight
		RF	RTJ	BW			RF/BW (lb/kg)
2	2	11.5	11.63	11.5	15.16	441	75/66
50	51	292	295	292	385	200	34/30
2 ½	2.5	13	13.13	13	16.93	551	99/88
65	64	330	333	330	430	250	50/45
3	3	14	14.13	14	18.7	617	152/137
80	76	356	359	356	475	280	69/62
4	4	17	17.13	17	26.97	661	286/267
100	100	432	435	432	685	300	130/121
5	5	20	20.12	20	30.31	881	419/385
125	125	508	511	508	770	400	190/175
6	6	22	22.13	22	35.43	991	551/518
150	150	559	562	559	900	450	250/235
8	7.87	26	26.13	26	35.94	1100	1002/947
200	200	660	663	660	913	500	455/430
10	9.76	31	31.13	31	41.73	23.62	1806/1692
250	248	787	790	787	1060	600	820/768
12	11.73	33	33.13	33	48.23		
300	298	838	841	835	1225		
14	12.87	35	35.12	35	52.28		
350	327	889	891	889	1328	-	
16	14.76	39	39.13	39	61		
400	375	991	994	991	1550	-	
18	16.5	43	43.13	430	66.93		
450	419	1092	1095	1092	1700	-	
20	18.27	47	47.25	47	70.87		
500	464	1194	1200	1194	1800	-	

The dimension and weights are for reference only and subject to change without notice.

1. For more dimensional information, please contact our sales representative.
2. "W" on above schematic is the diameter for hand wheel, the one without dimension on the table above is defaulted by gear operation.

GLOBE VALVE

DIMENSIONS AND WEIGHTS (Bolted Bonnet)

ASME CLASS 900 (PN 150)

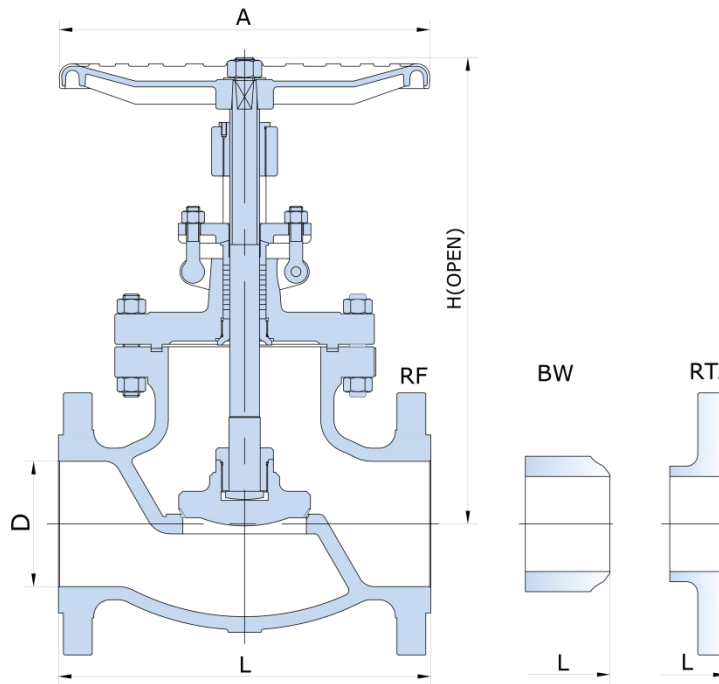

ASME CLASS 900 (PN 150)

Size in/mm	D	L			H	W	Weight
		RF	RTJ	BW			RF/BW (lb/kg)
2	1.87	14.5	14.63	14.5	17.5	9.84	152/143
50	47.5	368	371	368	445	250	69/65
2 1/2	2.24	16.5	16.62	16.5	19.5	11.81	231/216
65	57	419	422	419	502	300	105/98
3	2.87	15	15.13	15	21	13.78	238/220
80	73	381	384	381	533	350	108/100
4	3.86	18	18.13	18	24.5	15.75	352/319
100	98	457	460	457	622	400	160/145
5	4.76	22	22.13	22	27.16	17.72	617/562
125	121	559	562	559	690	450	280/255
6	5.75	24	24.13	24	29.5	19.7	771/711
150	146	610	613	610	750	500	350/323
8	7.48	29	29.13	29	36.5	19.7	1564/1487
200	190	737	740	737	927	500	710/675
10	9.37	33	33.13	33	44.88	-	
250	238	838	841	838	1140	-	
12	11.1	38	38.13	38	53.12	-	
300	282	965	968	965	1350	-	
14	12.24	40.5	40.88	40.5	55.12	-	
350	311	1029	1039	1029	1400	-	
16	14	44.5	44.88	44.5	63	-	
400	356	1130	1140	1130	1600	-	
18	15.75	48	48.5	48	68.9	-	
450	400	1219	1232	1219	1750	-	
20	17.52	52	52.5	52	72.83	-	
500	445	1321	1334	1321	1850	-	

The dimension and weights are for reference only and subject to change without notice.

- For more dimensional information, please contact our sales representative.
- "W" on above schematic is the diameter for hand wheel, the one without dimension on the table above is defaulted by gear operation.

GLOBE VALVE

DIMENSIONS AND WEIGHTS (Bolted Bonnet)

ASME CLASS 1500 (PN 250)

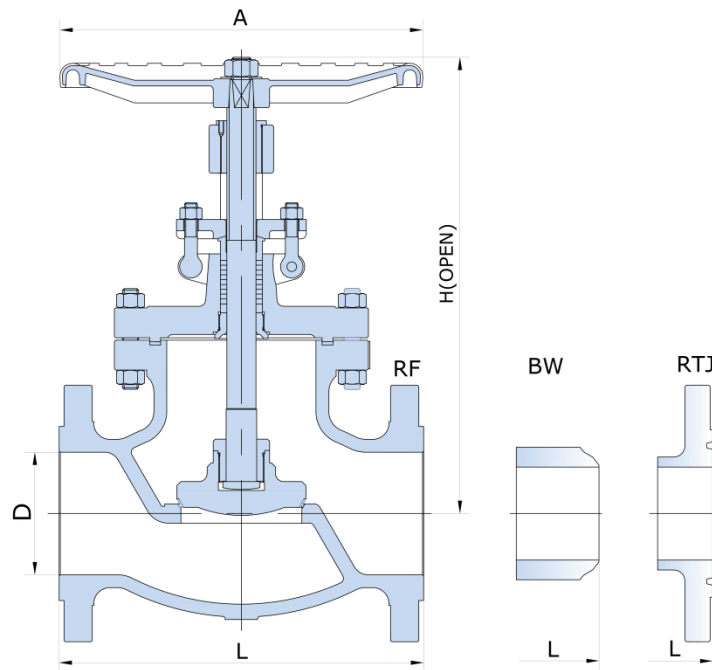

ASME CLASS 1500 (PN 250)

Size in/mm	D	L			H	W	Weight
		RF	RTJ	BW			RF/BW (lb/kg)
2	1.87	14.5	14.61	14.5	16.93	11.81	161/150
50	47.5	368	371	368	430	300	73/68
2 1/2	2.24	16.5	16.61	16.5	19.69	13.78	253/231
65	57	419	422	419	500	350	115/105
3	2.76	18.5	18.62	18.5	29.53	15.75	324/291
80	70	470	473	470	750	400	147/132
4	3.58	21.5	21.61	21.5	32.28	17.72	436/319
100	91	546	549	546	820	450	198/182
5	4.73	26.5	26.61	26.5	34.65	19.7	771/731
125	111	673	676	673	880	500	350/332
6	5.35	27.75	28	27.75	35.83	23.6	1123/1068
150	136	705	711	705	910	600	510/485
8	7	32.75	33.15	32.75	39.96	-	-
200	178	832	842	832	1015	-	-
10	8.74	39	39.41	39	40.75	-	-
250	222	991	1001	991	1035	-	-
12	10.35	44.5	45.12	44.5	53.15	-	-
300	263	1130	1146	1130	1350	-	-
14	11.38	49.5	50.24	49.5	57.48	-	-
350	289	1259	1276	1259	1460	-	-
16	13	54.5	55.35	54.5	61	-	-
400	330	1384	1406	1384	1550	-	-
18	14.61	60.5	61.38	60.5	64.57	-	-
450	371	1537	1559	1537	1640	-	-
20	16.38	65.5	66.38	65.5	66.93	-	-
500	416	1664	1686	1664	1700	-	-

The dimension and weights are for reference only and subject to change without notice.

1. For more dimensional information, please contact our sales representative.
2. "W" on above schematic is the diameter for hand wheel, the one without dimension on the table above is defaulted by gear operation.