

GATE VALVE

OVERVIEW (Bolted Bonnet)

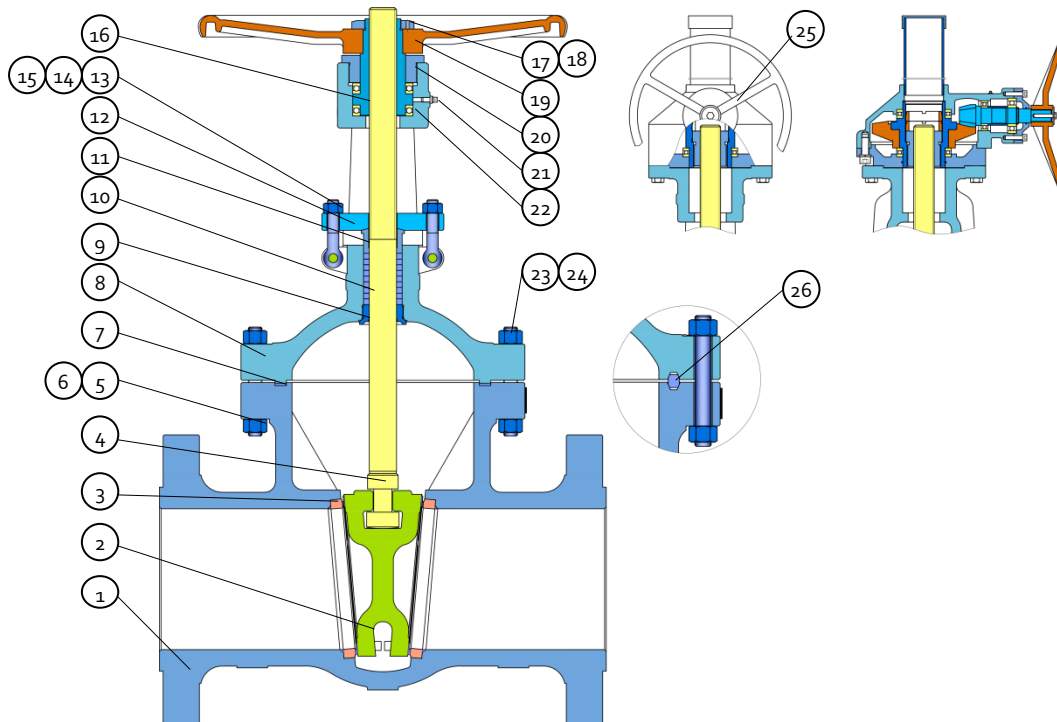

Part List

① Body	⑦ Gasket	⑬ Eye Bolt	⑲ Handwheel	⑳ Gear
② Wedge	⑧ Bonnet	⑭ Nut	㉑ Bearing Nut	㉒ Octagonal Ring
③ Seat	⑨ Backseat	⑮ Pin	㉓ Lubricating Nipple	
④ Stem	⑩ Packing	⑯ Stem Nut	㉔ Bearing	
⑤ Stud	⑪ Gland	⑰ Handwheel Nut	㉕ Stud	
⑥ Nut	⑫ Gland Flange	⑱ Screw	㉖ Nut	

Standards

Design & Manufacture API 600, ASME B16.34, MSS SP-144

Face-to-face ASME B16.10

End Dimension ASME B16.5 (RF, RTJ),
ASME B16.47 (RF, RTJ)
ASME B16.25 (BW)

Test & Inspection API 598

Typical Materials

Body, Bonnet, Disc	(Casting): A216 WCB, A351 CF3, CF8, CF3M, CF8M, A995 4A, 5A, A352 LCB, LCC, LC2
	(Forging): A105, A350 LF2, LF3, LF5, A182 F304, F304L, F316, F316L, F51, F53, F5, F11, F22, F91, Monel, Inconel, Hastelloy
Stem	A182 F6a, F304, F304L, F316, F316L, F51, F53, F55 Monel, Inconel, Hastelloy

GATE VALVE

DIMENSIONS AND WEIGHTS (Bolted Bonnet)

ASME CLASS 150 (PN 20)

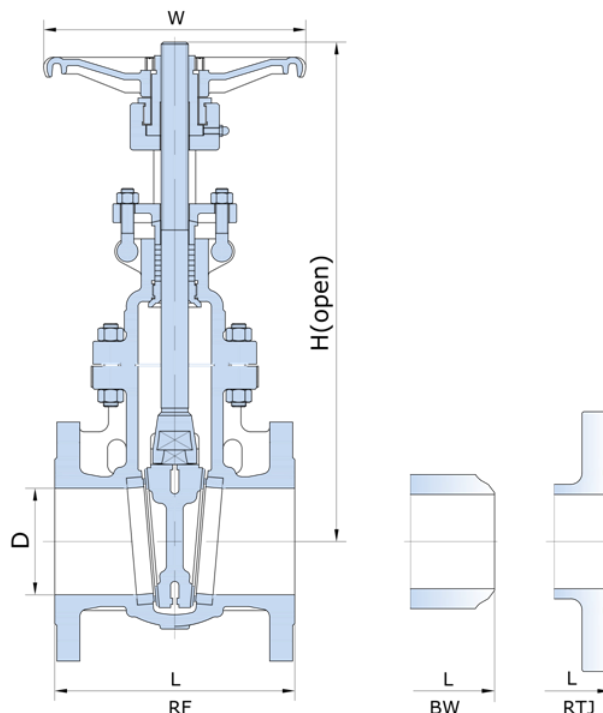

ASME CLASS 150 (PN 20)

Size in/mm	D	L			H	W	Weight
		RF	RTJ	BW			RF/BW (lb/kg)
2	2	7	7.5	8.5	15.87	7.87	40/33
50	51	178	191	216	403	200	18/15
2 1/2	2.5	7.5	8	9.5	18.9	7.87	55/40
65	64	190	203	241	480	200	25/18
3	3	8	8.5	11.12	20.12	9.84	70/57
80	76	203	216	283	511	250	32/26
4	4	9	9.5	12	23.7	11	110/90
100	100	229	242	305	602	280	50/41
5	5	10	10.5	15	30.91	11.81	143/130
125	125	254	267	381	785	300	65/59
6	6	10.5	11	15.88	34.84	11.81	170/152
150	150	267	280	403	885	300	77/69
8	8	11.5	12	16.5	38.5	13.78	267/238
200	203	292	305	419	978	350	121/108
10	10	13	13.5	18	46.93	15.75	392/344
250	250	330	343	457	1192	400	178/156
12	12	14	14.5	19.75	55	17.72	584/546
300	305	356	369	502	1397	450	265/248
14	14	15	15.5	22.5	62.32	19.69	800/727
350	337	381	394	572	1583	500	363/330
16	15.24	16	16.5	24	67.76	23.62	1020/934
400	387	406	419	610	1721	600	463/424
18	17.24	17	17.5	26	76.77	26.77	1368/1293
450	438	432	445	660	1950	680	621/587
20	19.25	18	18.5	28	85.35	28.35	1744/1656
500	489	457	470	711	2168	720	792/752
22	21.26	20	20.5	30	92.52	29.53	2313/2093
550	540	508	521	762	2350	750	1050/950
24	23.27	20	20.5	32	105	29.53	2621/2520
600	591	508	521	813	2668	750	1190/1144
26	25.24	22	-	34	-	-	3350/3458
650	641	559	-	864	-	-	1521/1570
28	27.24	24	-	36	-	-	4048/4185
700	692	610	-	914	-	-	1838/1900
30	29.25	24	-	36	-	-	24980/6608
750	743	610	-	914	-	-	261/3000

The dimension and weights are for reference only and subject to change without notice.

1. For more dimensional information, please contact our sales representative.

2. "W" on above schematic is the diameter for hand wheel, the one without dimension on the table above is defaulted by gear operation.

GATE VALVE

DIMENSIONS AND WEIGHTS (Bolted Bonnet)

ASME CLASS 300 (PN 50)

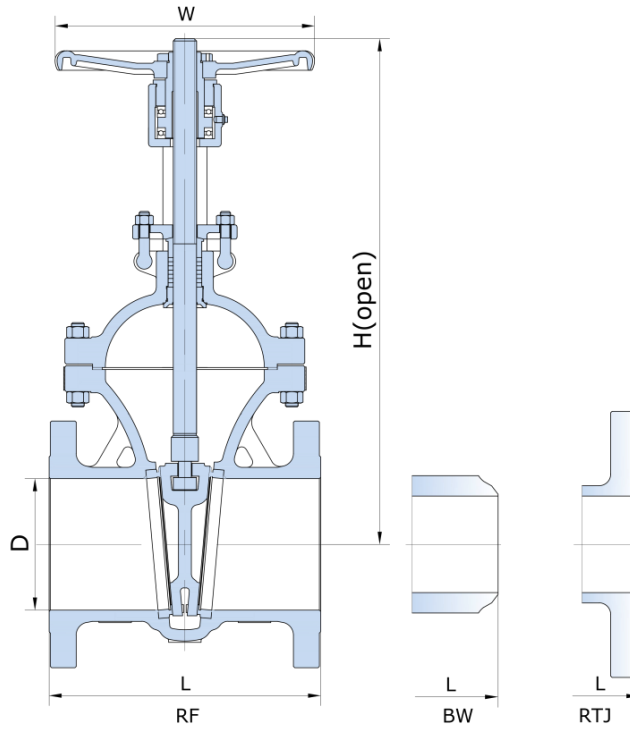

ASME CLASS 300 (PN 50)

Size in/mm	D	L			H	W	Weight
		RF	RTJ	BW			RF/BW (lb/kg)
2	2	8.5	9.13	8.5	17.05	7.87	51/37
50	51	216	232	216	433	200	23/17
2 1/2	2.5	9.5	10.12	9.5	18.54	7.87	77/57
65	64	241	257	241	471	200	35/26
3	3	11.1	11.73	11.1	21.06	9.84	110/86
80	76	282	298	282	535	250	50/39
4	4	12	12.64	12	24.7	11	156/117
100	100	305	321	305	627	280	71/53
5	5	15	15.63	15	28.15	11.81	256/200
125	125	381	397	381	715	300	116/91
6	6	15.87	16.5	15.87	32.44	13.78	317/249
150	150	403	419	403	824	350	144/113
8	8	16.5	17.13	16.5	39.53	15.75	460/361
200	203	419	435	419	1004	400	209/164
10	10	18	18.62	18	49.61	17.72	709/564
250	250	457	473	457	1260	450	322/256
12	12	19.76	20.39	19.76	58.27	19.7	1062/859
300	305	502	518	502	1480	500	482/390
14	14	30	30.63	30	63.19	-	1504/1244
350	337	762	778	762	1605	-	683/565
16	15.24	33	33.62	33	71.06	-	2093/1773
400	387	838	854	838	1805	-	950/805
18	17	36	36.61	36	78.54	-	2522/2126
450	432	914	930	914	1995	-	1145/965
20	19	39	39.76	39	94.69	-	3601/3106
500	483	991	1010	991	2405	-	1635/1410
22	21.8	43	43.86	43	100.4	-	5176/4626
550	553	1092	1114	1092	2550	-	2350/2100
24	23	45	45.87	45	104.33	-	5859/5077
600	584	1143	1165	1143	2650	-	2660/2305
26	25	49	50	49	116.14	-	6806/5595
650	635	1245	1270	1245	2950	-	3090/2540
28	27	53	54	53	122.05	-	7291/6002
700	686	1346	1371	1346	3100	-	3310/2725
30	29	55	56	55	126	-	7919/6729
750	736	1397	1422	1397	3200	-	3595/3055

The dimension and weights are for reference only and subject to change without notice.

- For more dimensional information, please contact our sales representative.
- "W" on above schematic is the diameter for hand wheel, the one without dimension on the table above is defaulted by gear operation.

GATE VALVE

DIMENSIONS AND WEIGHTS (Bolted Bonnet)

ASME CLASS 600 (PN 100)

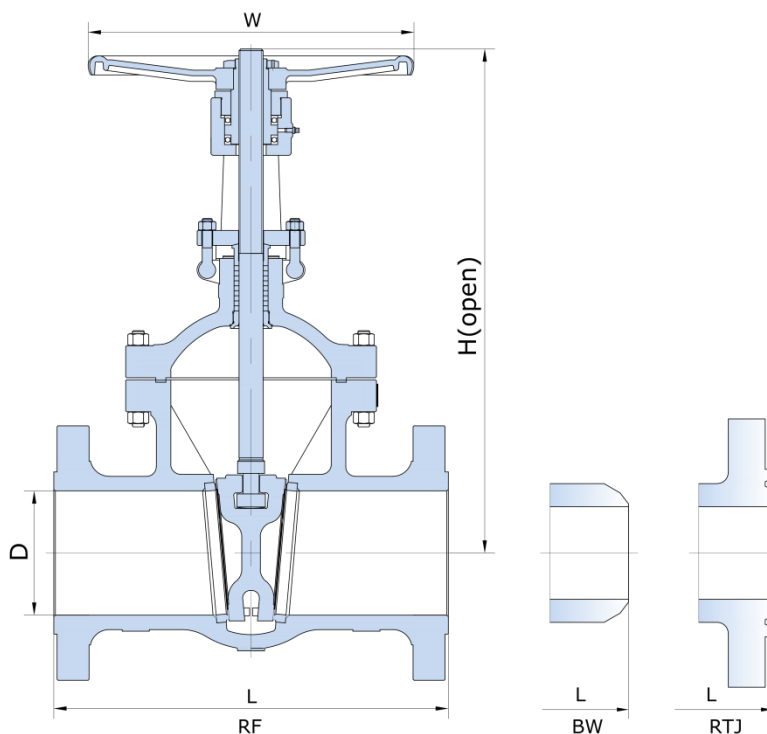

ASME CLASS 600 (PN 100)

Size in/mm	D	L			H	W	Weight
		RF	RTJ	BW			RF/BW (lb/kg)
2	2	11.5	11.63	11.5	16.5	441	79/64
50	51	292	295	292	418	200	36/29
2 1/2	2.5	13	13.13	13	18.75	551	115/93
65	64	330	333	330	476	250	52/42
3	3	14	14.13	14	20.38	617	148/117
80	76	356	359	356	518	280	67/53
4	4	17	17.13	17	25.5	661	247/183
100	100	432	435	432	646	300	112/83
5	5	20	20.12	20	29.5	881	330/267
125	125	508	511	508	750	400	150/121
6	6	22	22.13	22	33	991	374/275
150	150	559	562	559	840	450	170/125
8	7.87	26	26.13	26	40.38	1100	866/683
200	200	660	663	660	1025	500	393/310
10	9.76	31	31.13	31	48.38	23.62	1344/1040
250	248	787	790	787	1230	600	610/472
12	11.73	33	33.13	33	57	23.62	1960/1608
300	298	838	841	835	1450	600	890/730
14	12.87	35	35.12	35	62	-	2742/2324
350	327	889	891	889	1575	-	1245/1055
16	14.76	39	39.13	39	70.62	-	3370/2731
400	375	991	994	991	1795	-	1530/1240
18	16.5	43	43.13	43	76	-	4317/2786
450	419	1092	1095	1092	1930	-	1960/1625
20	18.27	47	47.25	47	87	-	5396/4471
500	464	1194	1200	1194	2210	-	2450/2030
22	20.12	51	51.38	51	97.24	-	6123/4956
550	511	1295	1305	1295	2470	-	2780/2250
24	22	55	55.38	55	101.5	-	6597/5705
600	559	1397	1407	1397	2580	-	2995/2590
26	23.74	57	57.5	57	105	-	7654/6289
650	603	1448	1461	1448	2665	-	3475/2855
28	25.51	61	61.5	61	109.5	-	8205/6751
700	648	1549	1562	1594	2780	-	3725/3065
30	27.36	65	65.5	65	114	-	8910/7489
750	695	1651	1664	1651	2895	-	4045/3400

The dimension and weights are for reference only and subject to change without notice.

- For more dimensional information, please contact our sales representative.
- "W" on above schematic is the diameter for hand wheel, the one without dimension on the table above is defaulted by gear operation.

GATE VALVE

DIMENSIONS AND WEIGHTS (Bolt Bonnet)

ASME CLASS 900 (PN 150)

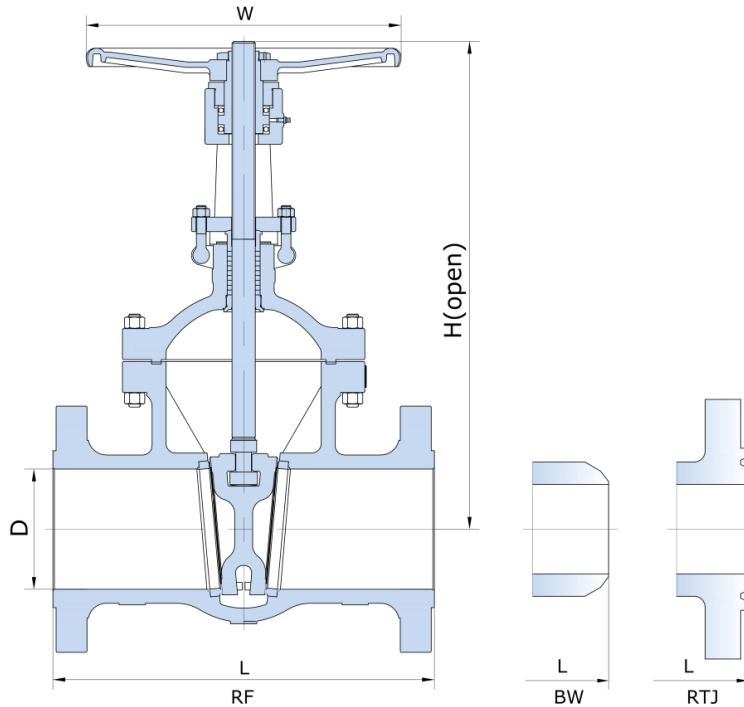

ASME CLASS 900 (PN 150)

Size in/mm	D	L			H	W	Weight
		RF	RTJ	BW			RF/BW (lb/kg)
2	1.87	14.5	14.63	14.5	19.62	7.87	163/119
50	47.5	368	371	368	498	200	74/54
2 ½	2.24	16.5	16.62	16.5	21.5	9.84	222/172
65	57	419	422	419	547	250	101/78
3	2.87	15	15.13	15	22.5	11.81	289/231
80	73	381	384	381	573	300	131/105
4	3.86	18	18.13	18	26.62	17.72	379/297
100	98	457	460	457	678	450	172/135
5	4.76	22	22.13	22	35.5	19.7	615/463
125	121	559	562	559	900	500	276/210
6	5.75	24	24.13	24	38.2	19.7	378/573
150	146	610	613	610	970	500	335/260
8	7.48	29	29.13	29	43.5	23.62	1410/1134
200	190	737	740	737	1103	600	640/515
10	9.37	33	33.13	33	53	-	2423/2026
250	238	838	841	838	1345	-	1100/920
12	11.1	38	38.13	38	60	-	3546/3040
300	282	965	968	965	1525	-	1600/1380
14	12.24	40.5	40.88	40.5	74.5	-	4956/4427
350	311	1029	1039	1029	1900	-	2250/2010
16	14	44.5	44.88	44.5	81	-	6278/5650
400	356	1130	1140	1130	2055	-	2850/2565
18	15.75	48	48.5	48	87	-	6740/5474
450	400	1219	1232	1219	2215	-	3060/2485
20	17.52	52	52.5	52	101	-	8447/7159
500	445	1321	1334	1321	2565	-	3835/3250
24	21	61	61.75	61	104	-	10793/8954
600	533	1549	1568	1549	2640	-	4900/4065

The dimension and weights are for reference only and subject to change without notice.

1. For more dimensional information, please contact our sales representative.
2. "W" on above schematic is the diameter for hand wheel, the one without dimension on the table above is defaulted by gear operation.

GATE VALVE

DIMENSIONS AND WEIGHTS (Bolted Bonnet)

ASME CLASS 1500 (PN 250)

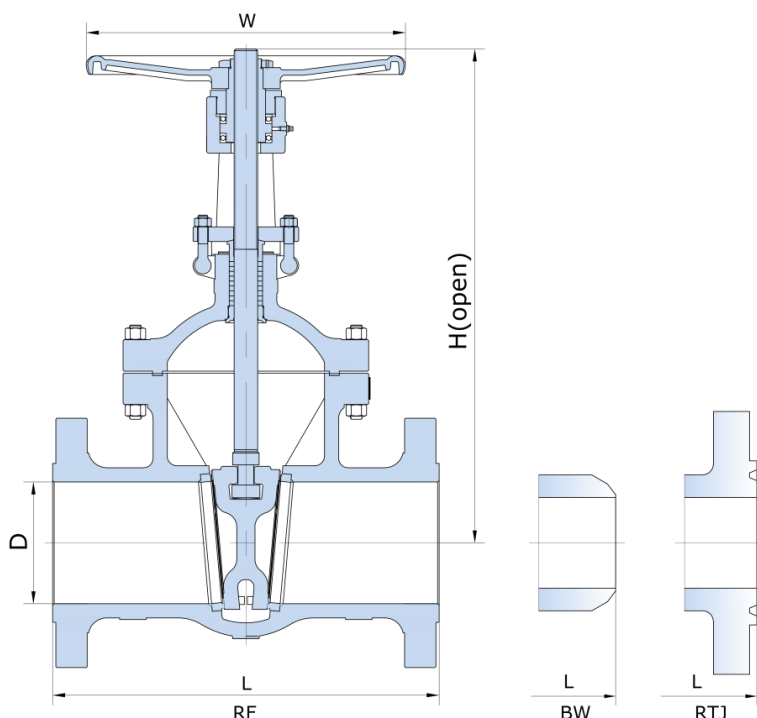

ASME CLASS 1500 (PN 250)

Size in/mm	D	L			H	W	Weight	
		RF	RTJ	BW			RF/BW (lb/kg)	
2	1.87	14.5	14.61	14.5	24.25	10	256/231	
50	47.5	368	371	368	615	250	116/105	
2 ½	2.24	16.5	16.61	16.5	26	12	366/330	
65	57	419	422	419	658	300	166/150	
3	2.76	18.5	18.62	18.5	30	18	460/414	
80	70	470	473	470	760	450	209/188	
4	3.58	21.5	21.61	21.5	34.12	20	652/584	
100	91	546	549	546	868	500	296/265	
5	4.73	26.5	26.61	26.5	38.4	24	958/826	
125	111	673	676	673	975	600	435/375	
6	5.35	27.75	28	27.75	39.5	24	1123/907	
150	136	705	711	705	1005	600	510/412	
8	7	32.75	33.15	32.75	45	-	2026/1586	
200	178	832	842	832	1145	-	920/760	
10	8.74	39	39.41	39	54	-	4207/3610	
250	222	991	1001	991	1370	-	1910/1640	
12	10.35	44.5	45.12	44.5	61	-	6947/6068	
300	263	1130	1146	1130	1650	-	3154/2755	
14	11.38	49.5	50.24	49.5	74.88	-	9031/7048	
350	289	1259	1276	1259	1900	-	4100/3200	
16	13	54.5	55.35	54.5	80.5	-	13656/11674	
400	330	1384	1406	1384	2050	-	6200/5300	
18	14.61	60.5	61.38	60.5	93.75	-	19747/17775	
450	371	1537	1559	1537	2350	-	8965/8070	
20	16.38	65.5	66.38	65.5	101.5	-	28855/25969	
500	416	1664	1686	1664	2580	-	13100/11790	
24	19.61	76.5	77.6	76.5	114.75	-	34934/31443	
600	498	1943	1971	1943	2915	-	15860/14275	

The dimension and weights are for reference only and subject to change without notice.

- For more dimensional information, please contact our sales representative.
- "W" on above schematic is the diameter for hand wheel, the one without dimension on the table above is defaulted by gear operation.